

DRONE MAKER

— User Guide —

WARNING

This device complies with Part 15 of the FCC Rules. Operation is subject to the following two conditions: (1) this device may not cause harmful interference, and (2) this device must accept any interference received, including interference that may cause undesired operation.

Written by David Meador.

Content advising by Paul Uttley.

Build creation and SolidWorks® Composer™ and KeyShot® renderings by Tim Lankford and Jason Redd.

Desktop publishing by Todd McGeorge.

©2022 Pitsco Education, LLC, 915 E. Jefferson, Pittsburg, KS 66762



All rights reserved. This product and related documentation are protected by copyright and are distributed under licenses restricting their use, copying, and distribution. No part of this product or related documentation may be reproduced in any form by any means without prior written authorization of Pitsco Education, LLC.

All other product names mentioned herein might be the trademarks of their respective owners.

Table of Contents

Drone Parts	2-3
Getting Started.....	4
Drone Assembly.....	5-7
Controller Functions.....	8-9
Drone Flight.....	10-11
Beyond the Build.....	12
Troubleshooting	13

DRONE PARTS

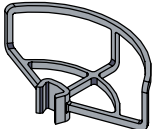
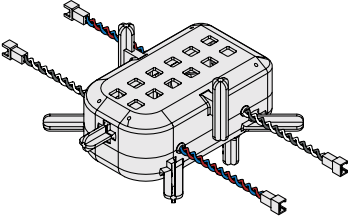
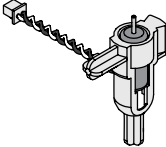
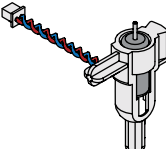
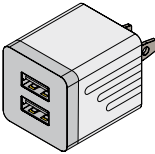
Part	Part Name	Quantity
	90-degree connector	10
	90-degree through connector	10
	Propeller guard	8
	Drone body	1
	Motor mounts with black and white wires	2
	Motor mounts with red and blue wires	2
	Charger	1

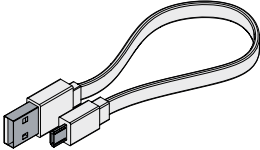
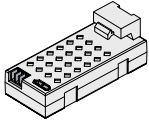
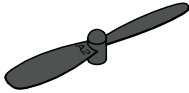
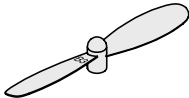
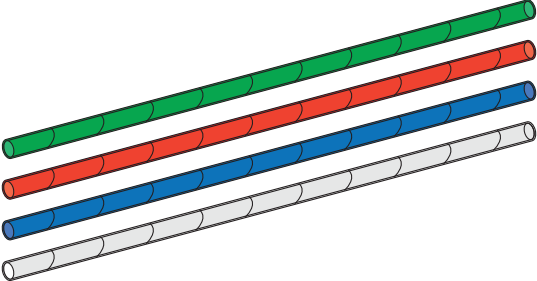
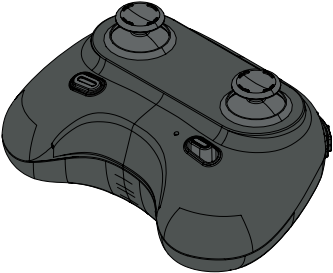
Part	Part Name	Quantity
	Micro USB cable	2
	Battery	2
	Propeller A	4
	Propeller B	4
	Body tube (colors vary)	16
	Remote control	1

Drones in the Air

Up, up, and away! Drones have taken everybody's imagination by storm in recent years. Promises of packages being delivered to your door with everything from hot fresh pizza to a new item from your favorite retailer, as well as the ability of first responders to reach remote locations with lifesaving equipment in a moment's notice – these are the dreams of a future with drones. But what is needed for any of this future to happen, engineering drones for these and other tasks? Welcome to the world of **aerospace engineering**, you now have the opportunity to figure out this future!

Did You Know?

In remote areas of Africa, drones are used for delivering medical shipments because it would take longer to deliver the items over land. You can read more about this lifesaving use for drones here: <https://dronedj.com/2022/02/18/zipline-expands-drone-deliveries-of-medical-supplies-to-kenya/>.

Design and Iterate

You have a system for building and adding to your drone that makes it quick and simple to make changes to the basic design of the drone. This will enable you to design, build, and test a drone and then make improvements to test the drone again. This design, test, and redesign process is known as **iteration**. Depending on the time you have available, the system you have will enable you to compare multiple possible solutions to a problem based on how well each solution is likely to meet the parameters that have been set.

GLOSSARY TERMS:

Aerospace Engineer – an engineer who works with designing, building, and testing aircraft, including drones, to meet goals

iteration – refining a product or process by tweaking the later version and then starting over

Batteries and Charging

In order for your drone to operate at maximum capacity, the batteries should be fully charged. Locate the charger, Micro USB cable, and batteries. Plug these in while building your drone.

Building a Basic Drone

What You'll Need

The following is the list of parts you will need to build the basic drone.

Drone Parts

Part Name	Quantity
Propeller guard	4
Drone body	1
Motor mounts with black and white wires	2
Motor mounts with red and blue wires	2
Battery	2
Propeller A	2
Propeller B	2
Body tube	4
Remote control	1

Putting Your Drone Together

Cut four body tubes to equal lengths. 45mm is a good length to start with. The tubes will attach to the drone body and motor mounts by sliding snugly over the connection points.

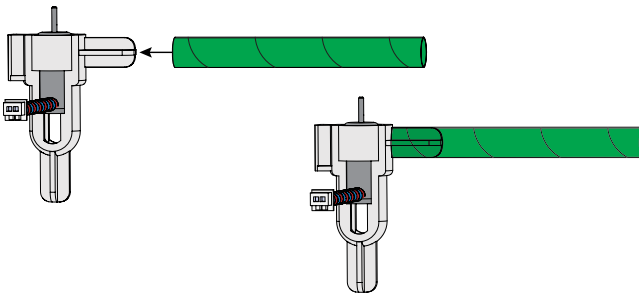

DRONE ASSEMBLY

Propeller and Propeller Guard

Before mounting the props, you should slide the propeller guards onto the motor mounts from the top.

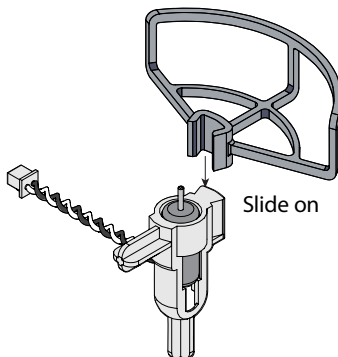

Motor/Propeller/Guard Assembly

The props need to be pressed onto the motor axle. You should match the props to the motors first. The props labeled "A" should be mounted on the red-and-blue wired motors, and the props labeled "B" should be mounted on the black-and-white wired motors.

Counterclockwise Propeller Mark

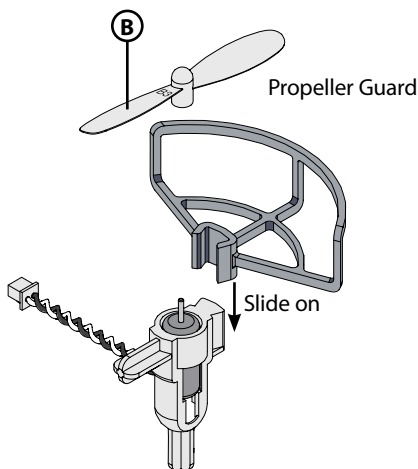

Counterclockwise Motor
(black and white wires)

Clockwise Propeller Mark

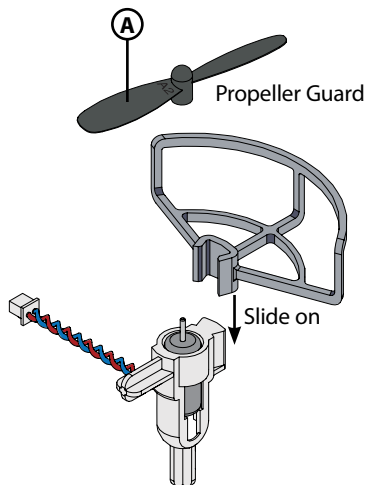

Clockwise Motor
(red and blue wires)

Aligning the Motors and Drone Body

When connecting the motors to the drone body, it is important to align them correctly. The motor wire coloring should match the wire coloring coming from the drone body. This is because the motors spin in opposite directions. Be careful when connecting and disconnecting the wires to prevent them from breaking. You will want to ensure that the motors are aligned with the body because any deviations can cause a reduced flight time from the batteries or an inability to take off.

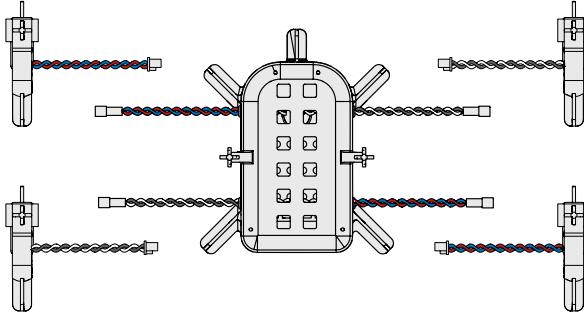

Basic Drone Design

To build a basic drone that will fly, use the following diagram.

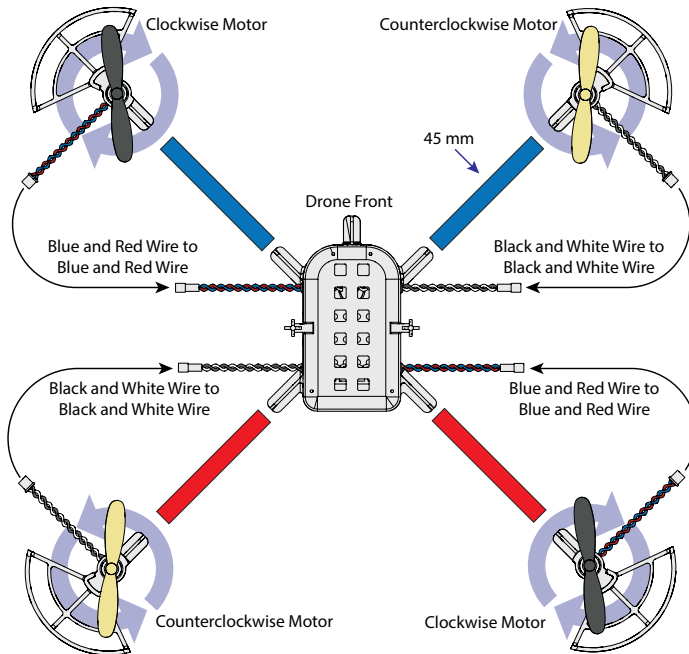

CONTROLLER FUNCTIONS

Drone Controller Functions

Refer to this diagram for the functions on the drone controller included with your kit.

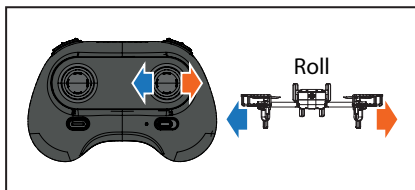
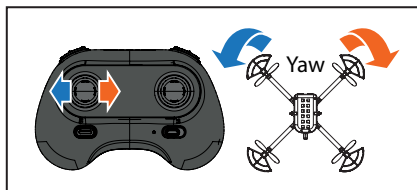
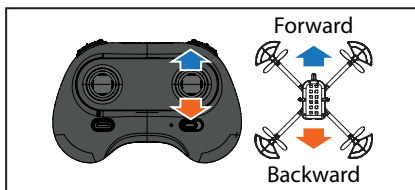
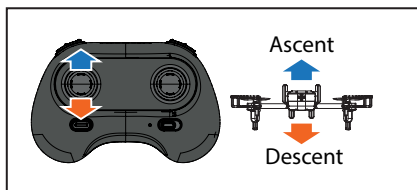
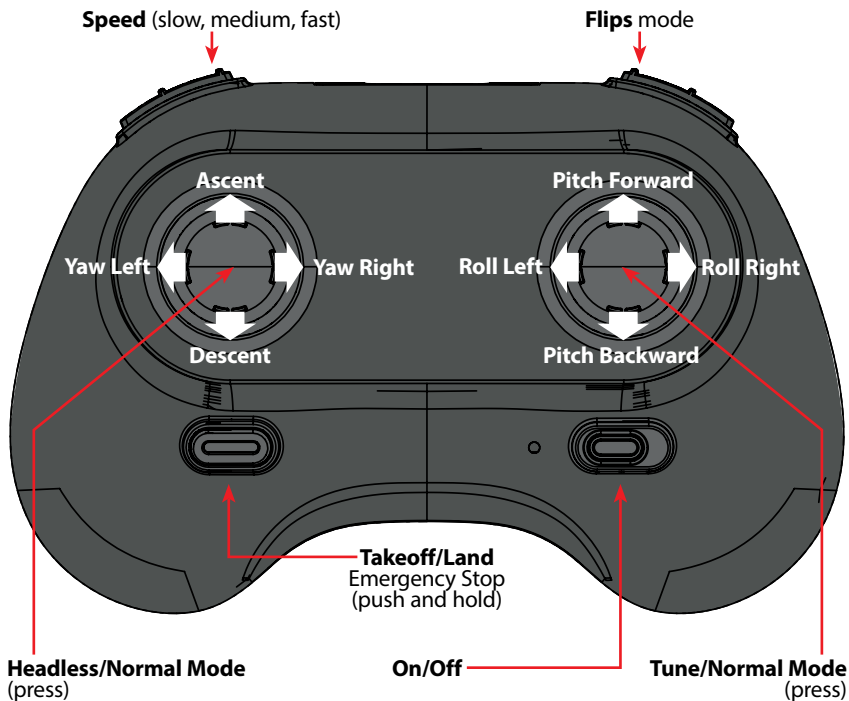

CONTROLLER FUNCTIONS

Speed – The drone’s responsiveness to the controller’s commands is adjusted into three different modes by pressing and releasing this button.

- *Slow* – The drone operates more gently to the commands input at the controller. This mode is recommended for a beginner drone pilot.
- *Medium* – The drone operates intuitively to the commands input by the controller. This mode is recommended as you gain experience as a drone pilot.
- *Fast* – The drone operates rapidly to any commands input by the controller. This mode is recommended only after extensive experience as a drone pilot.

Flips – When this button is pressed, the drone enters flip mode. While in flip mode, the right joystick on the controller can be used to perform a flip by pressing one of the four directions forward, backward, left, or right.

Ascent/Descent – This is the throttle; it controls the speed of the motors. Pushing up causes the drone to go straight up; pushing down causes the drone to go straight down.

Yaw Left/Yaw Right – Rotates the drone around the center of the drone body. It is used to change the direction the drone is pointing. Pushing left rotates the drone to the left; pushing right rotates the drone to the right.

Pitch Forward/Pitch Backward – Tilts the drone forward or backward. Pushing up tilts the drone forward, and it moves forward. Pushing down tilts the drone backward, and the drone moves backward.

Roll Left/Roll Right – Tilts the drone to the left or right. Pushing right tilts the drone to the right, and it moves to the right. Pushing left tilts the drone to the left, and the drone moves to the left.

Takeoff/Land – Pushing and releasing this button will make the drone take off when not flying and land when flying. Pushing and holding when the drone is in flight will activate the emergency landing feature, and the drone’s motors will immediately stop spinning, and the drone will fall directly to the ground.

Power On/Off – Pushing and releasing this button will turn the remote on or off.

Headless/Normal Mode – In normal mode, left and right are always in reference to the drone’s left and right. In headless mode, left and right are in reference to the controller’s left and right when facing the drone.

Tune/Normal Mode – In normal mode, the controls operate the motors to cause movement in the drone. In tune mode, the power sent to each of the motors is adjusted to balance the flight characteristics of the drone. Each time the drone is restarted, the previous tuning returns to the default.

Pairing the Remote and Taking Flight

Follow these steps to pair your remote and fly it. Remember to wear safety glasses when operating the drone.

1. After the drone is built, make sure the battery is fully charged before flying. Then, insert the battery into the drone body.
2. After the battery is in place, press and hold the power button on the bottom of the drone to power up the drone. The LED lights on the bottom will flash when the drone is powered up.
3. Turn on the drone and place it on a level surface. The drone indicator lights will blink slowly, which indicates it is waiting for pairing.

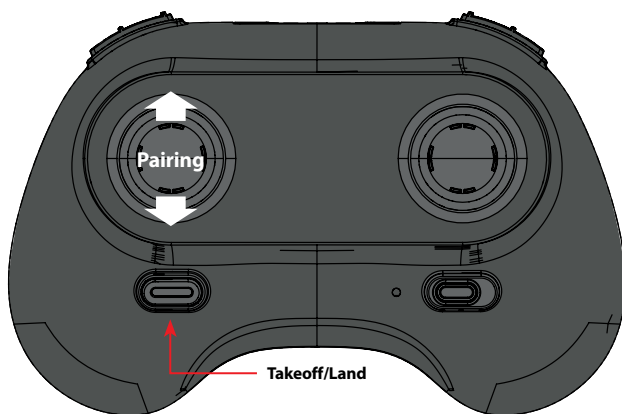

4. Power on the remote. The remote will beep once.
5. To pair, push the left joystick fully upward until you hear a beep and then fully downward until you hear a second beep. The indicator lights on the drone will change from blink to solid indicating a successful pair.
6. Press the Takeoff/Land button to start flight. The motors will begin spinning and the drone will rise one meter above the surface and hover.
7. Use the left and right joysticks to control the flight.
8. Flight time is approximately six to seven minutes depending on weight of drone.
9. Drone lights will blink to indicate low battery.
10. Drone will land automatically when battery is depleted, or press the Takeoff/Land button to land the drone.
11. Have a safe flight!



First Flight Activity

You're ready to fly! Use the following checklist to check off when you practice each of the skills as you practice flying your drone. Rate your skill from one to five on each skill. As with any skill, practice makes you better, so don't be discouraged if you aren't a five the first time. You might need to align your motors when taking off for the first time. Make sure the props on the motors are aligned with the drone's body. (**Hint:** You can use the connectors on the motor mounts and drone body to help you line up the motors and the body.) If the drone flies unpredictably or not at all, see the troubleshooting section of this guide for help.

Skill	Status
Pairing	1 2 3 4 5
Takeoff	1 2 3 4 5
Landing	1 2 3 4 5
Yaw left 180°	1 2 3 4 5
Yaw right 180°	1 2 3 4 5
Ascend one meter	1 2 3 4 5
Descend one meter	1 2 3 4 5
Roll left one meter	1 2 3 4 5
Roll right one meter	1 2 3 4 5
Pitch forward one meter	1 2 3 4 5
Pitch backward one meter	1 2 3 4 5
Navigate around an obstacle in Slow Speed Mode	1 2 3 4 5
Navigate around an obstacle in Medium Speed Mode	1 2 3 4 5
Navigate around an obstacle in Fast Speed Mode	1 2 3 4 5

Activity Extension

Find a way to construct the drone to make it easier to tell which is the front of the drone and which is the back of the drone when it is in flight. What's the biggest drone you can build and get in the air? What's the smallest drone you can build and get in the air?

Do Some Engineering!

On the drone body and the motor mounts are connection points where you can attach additional support beams. You can use these to engineer supports for carrying packages for delivery or adding landing struts to the drone. Your imagination is your limit! You also have some frame expansion connectors you can use to help design and build other capabilities into your drone.

Drone Frame Expansion Connectors

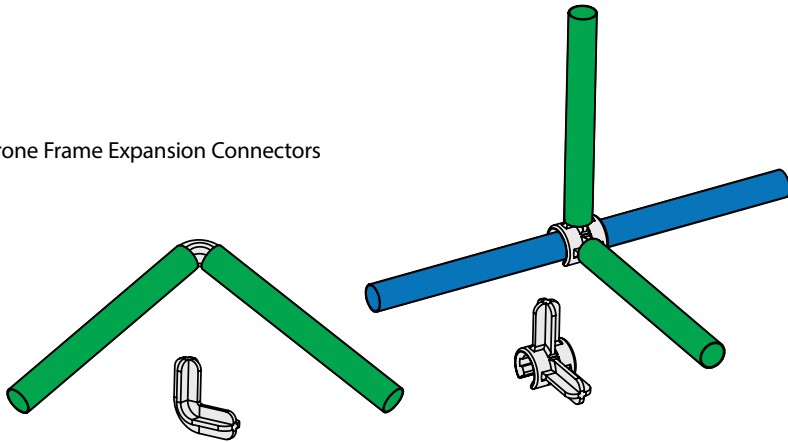

The tubes will also fit snugly into the through portion of the 90-degree through connectors. These connectors can be used to create extensions for the drone. These extensions can be used to create drone features designed to carry payloads, extend the drone's landing footprint, or add accessories.

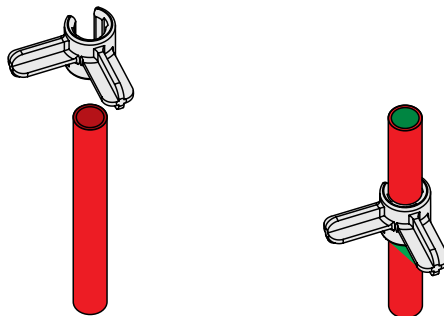

Design and build a drone to deliver some objects. But be careful – the more weight you add, the less flight time your drone will have. After you are successful, try and improve your design and make changes to your drone to make it more efficient in carrying the load.

Troubleshooting

Problem	Possible Solutions
Drone won't take off.	<p>The drone is too heavy. The maximum weight the drone can lift is between 65 and 75 grams. The drone with the battery in its lightest configuration is about 50 grams.</p> <p>The props are flipped. If the A and B props are on the wrong motors, they will push down instead of up, preventing the drone from taking off.</p> <p>The battery is too low. When the battery is critically low, the drone will land automatically and will not take off.</p>
Drone flips over on the ground when taking off.	Two of the props are not on the correct motors. The A and B props must be on the correct motors; if two are correct and two are incorrect, the drone will flip over during takeoff.
Drone flies erratically or spins after taking off.	The motors might not be aligned correctly. If one or more motors are not aligned in the same plane as the others, the drone will fly erratically; drift left, right, forward, or backward; or fly in circles after takeoff. This can also happen if one or more drone arms are damaged or bent. This will require replacing the damaged drone arm to fix.
Drone drifts toward one of the motors.	This usually indicates that one of the arms of the drone is a different length than the others. You should ensure all the drone arms are the same length. This can also happen if one of the drone motors is damaged and not spinning as fast as the other motors. The only solution to this is replacing the motor.





HAVE QUESTIONS?

There are a variety of ways
to get in touch with us:

Call us at 800-358-4983.

Email us at support@pitsco.com.

Chat with us on Pitsco.com/Support.

PITSCO
EDUCATION